

Dual Motor Standing Desk Installation Manual

UP1A-01

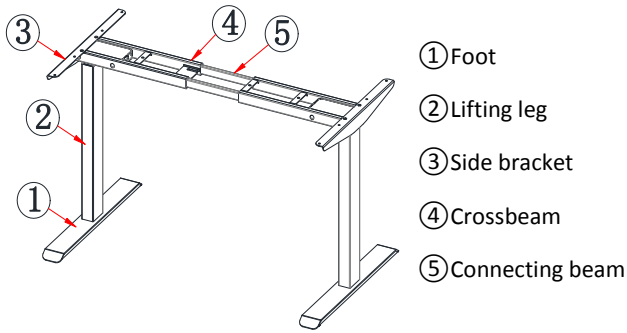

Parts Included		Qty
A	Screw M6x10	16
B	Screw M6x16	8
C	Screw M6x45	4
D	Wood screw ST4.8x19	11
E	Wood screw ST4.2x16	2
F	Allen wrench 4mm	1
G	Cable clip	5
H	Handset	1
I	Control box	1
J	Power cable	1

Step 1

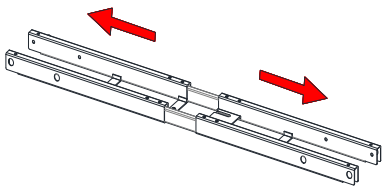

Fully separate the Crossbeams (part 4) you will find the Connecting beams (part 5) inside.

Step 2

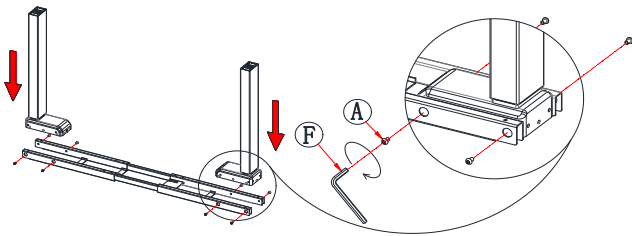

Attach the Lifting leg (part 2) to the Crossbeam (part 4) using (part A) Screw M6x10.

Step 3

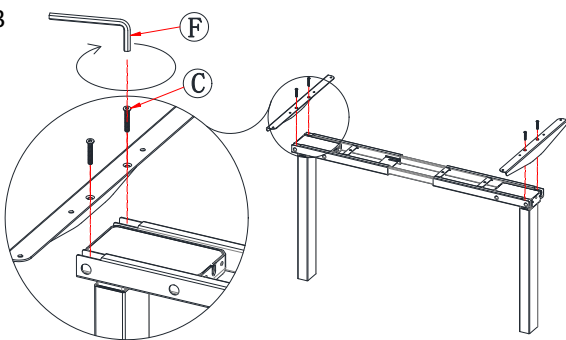

Attach the Side bracket (part 3) to the Crossbeam (part 4) using (part C) Screw M6x45.

Step 4

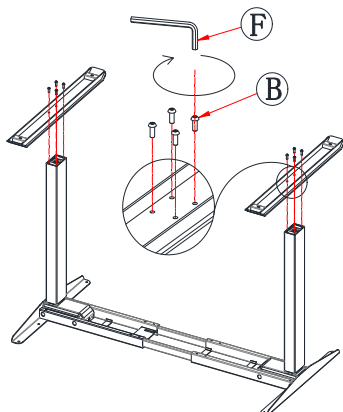

Attach Foot (part 1) to the Lifting leg (part 2) using (part B) Screw M6x16.

Step 5

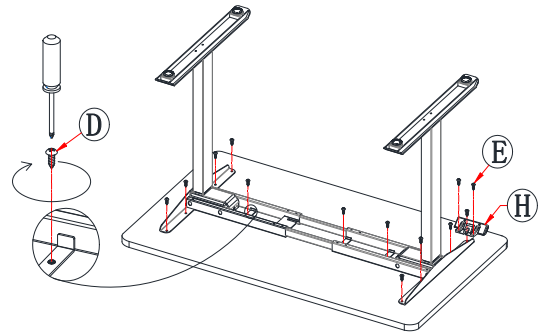

Adjust Crossbeams to the proper position to fit the desktop. Tighten the (part D) Wood screw ST4.8x19 to lock. Attach the Handset (part H) to the underside of the desktop using (part E) Wood screw ST4.2x16.

Step 6

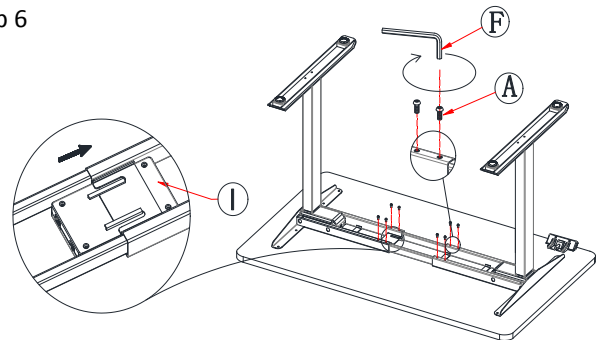

Tighten Crossbeams (part 4) using (part A) Screw M6x10. Attach the Control box (part I) to the Crossbeams.

Step 7

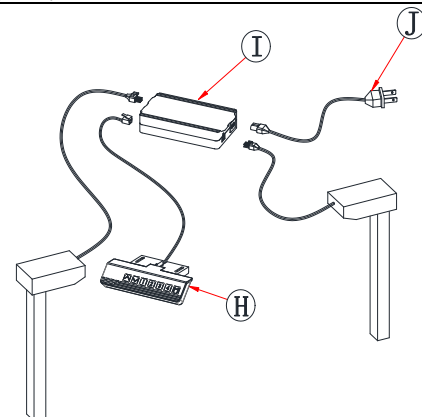

Connect the Lifting legs (part 2), Handset (part H), and the Power cable (part J) to the Control box (part I).